

THANK YOU

Congratulations on your recent purchase! We at Stryker know that you have a choice when it comes to your archery equipment, and we want to thank you for choosing us as your hunting partner. Your feedback is important to us, as it is our desire to provide you with the absolute finest products and customer service in the industry. Please take the time to go online and register your new Stryker crossbow. It is equally important to read through this owner's manual as there are valuable tips to help keep your Stryker trouble free for many seasons.

We encourage you to contact and utilize your local Authorized Stryker Dealers as they can assist you with purchases, services and accessories. To locate the dealer nearest you, visit Strykerxbow.com and click on the Dealer Locator button.

BEFORE USING YOUR NEW STRYKER CROSSBOW, READ AND UNDERSTAND THE FOLLOWING MATERIAL OUTLINED IN THIS MANUAL. FAILURE TO FOLLOW ANY OF THESE WARNINGS AND INSTRUCTIONS CAN DAMAGE THE CROSSBOW AND MAY CAUSE SERIOUS INJURY TO YOURSELF AND/OR OTHERS.

DISCLAIMER OF LIABILITY: By accepting a Stryker product, the buyer agrees to hold harmless Stryker and all associated parties from liability for any damage to persons or property, which may result, for any reason, from the use of this product.

QUALITY

Every Stryker crossbow has undergone a comprehensive quality control process and is built from the highest quality components available. All have been individually shot, tested and measured to ensure compliance with our strict performance standards.

TABLE OF CONTENTS

Lifetime Warranty	1-2	How To Properly Cock the Crossbow	5
Exclusions	1	How To Properly Load a Bolt	6
Warranty Service	2	Shooting the Crossbow	6
Crossbow Maintenance	2	Notes	7
Strings & Cables	3	Purchase Records	7
Safety & General Information	3-4		
Assembling Your New Solution Crossbow	4		

LIFETIME WARRANTY

This warranty protects against any failures of the product due to defects in material or workmanship and does not include any damage due to abuse, misuse or modification to the bow's design. The following exclusions apply.

EXCLUSIONS

Bows purchased through ebay or other community commerce web sites.

Cables and strings, string stops, bearings, paint and/or hydrographic film transferred finishes, accessories to include: sights, scope, string silencers, sling, quivers, or any other components included as part of an accessory package.

Damage caused by abuse, mishandling, dry-firing, alteration or modification to original product. Other excluded damages are those resulting from either shooting bolts less than 380 grains total weight, flat nocks, broken nocks or damaged bolts.

LIFETIME WARRANTY CONT.

For the warranty to be enforceable the original purchaser must complete and submit the online registration form within 30 days of purchase.

WARRANTY SERVICE

Our goal with all warranty returns is to have the bow shipped out the door and on its way back to your dealer within 3 business days of receiving it at our facilities in Eugene, Oregon. You are our greatest asset, and we will give you the highest quality and most efficient service possible.

All products requiring warranty service must be returned to an Authorized Dealer for inspection and diagnosis of any problem. Your Stryker dealer can determine whether factory service is required, or if the service needed can be performed at the dealer's facility. In the event that a bow must be returned for factory service, a

Return Authorization (RA) number must first be obtained by your dealer. Bows returned to the factory without an RA number will not be accepted.

The bow owner is responsible for the return prepaid freight to Stryker. No COD shipments will be accepted. Stryker will perform the warranty service required and return the product to the dealer prepaid.

- »» All methods of shipping by UPS or FED-EX only. Sender should insure all shipments.
- »» If your bow cannot be repaired, we reserve the right to replace your bow with a newer model of equal or greater value.
- »» Stryker reserves the right to substitute any parts required for warranty coverage at its sole discretion and for any reason.

CROSSBOW MAINTENANCE

Your Stryker crossbow was made with the highest quality components to last for a lifetime of use in the field with proper maintenance. If the crossbow is dry fired at any time, from broken nock or not having the bolt touching the string before firing, take it to your local dealer for a complete inspection. Never leave your Stryker bow in an area of extreme temperatures. This will cause your string and cables to stretch which effects timing.

- »» Before shooting your crossbow, always inspect the string and cables and check the limbs for any visible damage. If damage is found,

take the bow to your local Stryker dealer for inspection or repair.

- »» Your Stryker crossbow comes equipped with sealed bearings in both cams. There is no need to lubricate cams.
- »» Lube the rail. We recommend Scorpion Venom rail lube. Keeping your rail lubed will greatly increase serving life.
- »» Lube the cable slide. The cable slide track should be lubed occasionally with a small amount of grease or Scorpion Venom rail lube.

STRINGS & CABLES

Your Stryker custom bowstring is manufactured to provide long string life and absolute consistency, shot after shot. This results in greater accuracy and less time spent re-tuning your equipment.

Wax the string often. We recommend BCYML 6 synthetic string wax or an equivalent product. To wax the string, apply wax liberally to entire length of string. Rub briskly with fingers until the string appears slick. Remove all excess wax with a clean cloth.

If you need assistance with setting up, tuning or solving an arrow flight problem, contact your Authorized Stryker Dealer.

SAFETY & GENERAL INFORMATION

Your new Stryker crossbow is a highly tuned, precise shooting machine. It requires special care and handling to achieve and maintain peak performance. The string, cables and limbs are under extreme tension, which creates an incredible source of energy that must not be taken for granted. Please respect this power and use it properly.

ADULT SUPERVISION OF ALL CHILDREN UNDER THE AGE OF 18 IS REQUIRED Stryker has designed your crossbow to be a safe and fun product. However, as with any shooting style product, safety rules must be observed. It is **HIGHLY** recommended that these rules be read before using any bow.

Crossbows and arrows/bolts are NOT toys. For maximum safety and enjoyment, always exercise caution and common sense when shooting any bow.

WARNING: ALWAYS wear safety glasses when shooting or adjusting your crossbow.

ALWAYS use moon nocks or universal nocks (See Figure 1).

NEVER use a flat style nock.

ALWAYS use an appropriate backstop for maximum safety. An appropriate backstop must be constructed of a durable material and must extend beyond the perimeter of the target. The recommended backstop size is determined by the accuracy and ability of the shooter. With a low level of shooter accuracy, the backstop perimeter requirement must be increased appropriately.

NEVER aim or draw any bow in the direction of a person. Aim and draw **ONLY** in the direction of an appropriate target. **ALWAYS** have a full view of the path to and beyond the target when shooting.

ALWAYS inspect arrow, nock and fletching prior to shooting for imperfections such as cracks, splits or splinters. Most arrow manufacturers recommend a flex test on the shafts. Damaged arrows must not be used and should be destroyed.

NEVER retrieve arrows or allow anyone else to do so until all arrows have been shot.

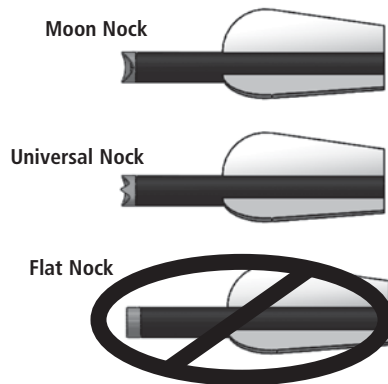

Figure 1: Always use Moon Nocks or Universal Nocks in your bow



Figure 2: Positioning and attaching the rail, grip shield, and stock.

SAFETY & GENERAL INFORMATION (CONT.)

DO NOT attach anything to the cables or string that could create excessive wear or slice the string material. This will void the warranty.

DO NOT cross cables in any configuration other than the configuration set by the factory. This will have an adverse effect on the performance and shootability of your bow. Further, it may cause extreme wear to the string, cable, and cable-slide/roller guard.

DO NOT shoot a bolt under 380 grains Including tip.

DO NOT shoot bolts with flat nocks (See Figure 1).

DO NOT shoot a bolt shorter than 20 inches.

DO NOT adjust the limb bolts.

DO NOT apply lubricant in the trigger housing.

DO NOT leave crossbow cocked longer than 10 hours.

DO NOT transport cocked or loaded crossbow.

DO NOT store crossbow in the cocked position.

NEVER PUT ANY PART OF YOUR BODY IN THE STRING PATH.

Any alteration from the factory specifications or the adjustments outlined herein will void the factory warranty. ALL maintenance must be performed at an Authorized Stryker Dealer.

ASSEMBLING YOUR NEW SOLUTION CROSSBOW

You will need a #2 Philips head screwdriver and a 9/64 Allen wrench.

1. Take all the pieces out of the box. The stock, stirrup, screws and accessories are located on the sides of the box below the bow and rail assembly.
2. Locate the 3 Philips head screws, grip shield, and the stock.
3. Lay the stock on the rail as shown in **Figure 2**, then lay the grip shield on the stock (see **"Assembling the Grip Shield"**). Make sure the stock and grip shield holes are lined up with the holes in the rail.
4. Place a screw in each of the 3 holes on the stock. If different length screws were provided, place the shortest screw in the back hole closest to the butt plate.
5. Tighten the screw closest to the cables first, then tighten the screw closest to the recoil pad, lastly tighten the center screw. Do not over tighten the screws (torque to 19 inch pounds)!

ASSEMBLING YOUR NEW SOLUTION CROSSBOW (CONT.)

- Place the stirrup on the riser as shown in Figure 2, make sure the counter bores are facing up.
- Insert the 4 socket head cap screws into the counter bored holes.
- Tighten all 4 screws to 20 inch pounds.
- Your bow is now ready to shoot.

POSITIONING THE GRIP SHIELD

Ensure that the short end of the grip shield (see Figure 3) faces the front (limbs) of the crossbow. If different length screws were provided, place the two longer screws in the grip shield sockets.

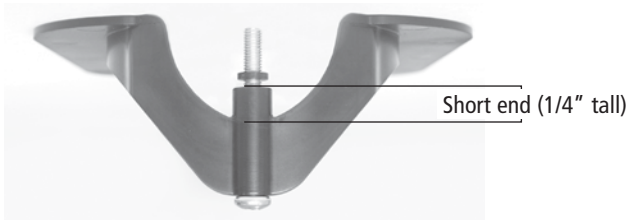
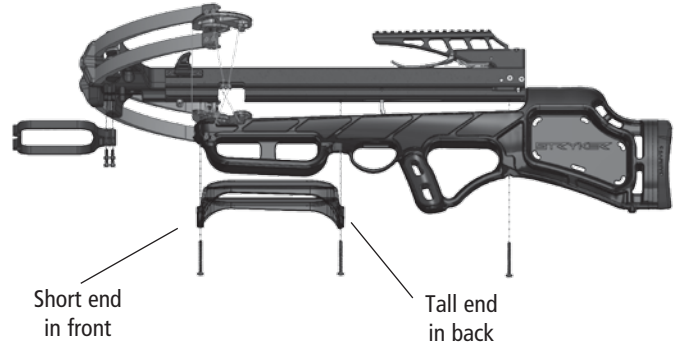

Forward facing

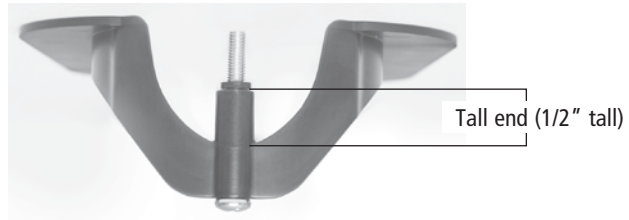

Rear facing

Figure 3: Positioning grip shield

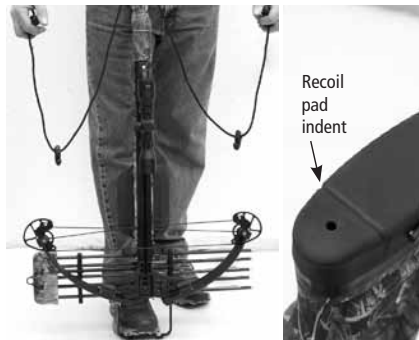

Figure 4



Figure 5

HOW TO PROPERLY COCK THE CROSSBOW

1. Place foot in stirrup
2. Put rope around back of recoil pad (see Figure 4). Make sure the rope is placed in the recoil pad indent, if available.
3. Put hooks on the bow string (make sure hook is in the orientation shown—facing up and toward you [see Figure 5]).
4. Pull the handles up and towards your body until you hear the click of the trigger resetting—the safety will automatically be set in the “safe” position (see figure 6). If the handles are not pulled towards your body, the hooks will pull up over the rail. If this happens, slowly let the crossbow down to the rest position, reposition the hooks on the sides of the rail and start again at step 1.

5. Release the tension off the handles and the hooks should fall off the string.

6. Install the Cease-Fire safety pin into the trigger shell (see Figure 7). The Cease-Fire pins can go in on either side of the shells.

7. Your crossbow is now ready to have a bolt loaded.

Figure 7: Insert Cease-Fire secondary loading safety into ports after cocking.



Figure 6



HOW TO PROPERLY LOAD A BOLT



Figure 8

a damaged nock as it can cut the crossbow string and cause serious injury to the shooter and the crossbow!

3. Grasp the bolt within 1" of the tip (see Figure 8).
4. Put the bolt onto the rail with the cock vane (off colored vane) down in the rail.
5. Push the bolt back under the bolt sensor making sure that the nock is touching the string. Make sure that your hand and fingers are ALWAYS on the stirrup side of the rail and behind the broad head. This way the string and broad head blades can never hit your fingers.

1. Inspect the bolt by flexing it to make sure it is not damaged (if you hear any noises from the bolt when flexing, immediately throw the bolt away, it is not safe to shoot).

2. Inspect the nock to make sure that it is properly aligned with the cock vane and is not damaged. Make sure the nock is fully seated in the bolt. Do not shoot a bolt with



Figure 9: Never put any part of your body in the string path.

6. Remove the Cease-Fire safety.
7. Your crossbow is now ready to shoot.



SHOOTING THE

1. Make sure that you have a clear path to the target and a safe backstop behind the target.
2. Grasp the forearm with your forward hand and make sure your fingers are below the string path (see Figure 9), and under the grip shield.
3. Move the safety forward to the fire position with your trigger hand.
4. Firmly grasp the grip with your trigger hand and slowly squeeze the trigger. This crossbow has a competition grade trigger and has a pull of less than 3 pounds, so do not touch the trigger until you are on the target and ready to fire.

NOTES

SERIAL NUMBER: _____

DATE PURCHASED: _____

AUTHORIZED DEALER: _____

STRYKER™
CROSSBOWS
90554 HWY 99 N
EUGENE, OR 97402